

**TYPE LF
INSTALLATION NOTES**



www.aercon.com

Prior to installation identify the inlet face of the stabiliser marked with the on the blades transfers and ensure that you install it from the room at higher pressure.

Cut an aperture in the wall as close as possible to the minimum aperture size shown in the brochure (and reproduced here for the particular stabiliser).

Ensure that the stabiliser is level in both planes and screwfix to the wall using No. 8 woodscrews through the holes provided.

White plastic screw caps are provided for appearance and ease of cleaning.

Insert the slip over rear flange from the low pressure side and attach using No. 8 woodscrews, as for the stabiliser.

Seal the joint between the stabiliser halves using suitable silicon mastic.

In the event of installation or operational problems, please contact the Aercon Division of Power Utilities Limited for further assistance.

Minimum Apertures for LF Valves

Stabiliser Range	Minimum Aperture
LF200/1 - LF750/1	Blade Width+40x136 high
LF200/2 - LF750/2	Blade Width+40x260 high
LF200/3 - LF750/3	Blade Width+40x384 high
LF200/4 - LF750/4	Blade Width+40x508 high
LF200/5 - LF710/5	Blade Width+40x632 high
LF200/6 - LF710/6	Blade Width+40x756high

Note: the number after the letters denotes the LF stabiliser blade width.

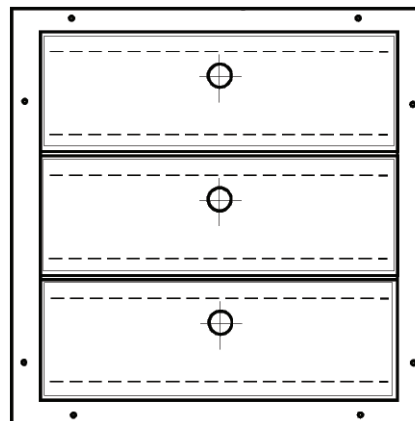
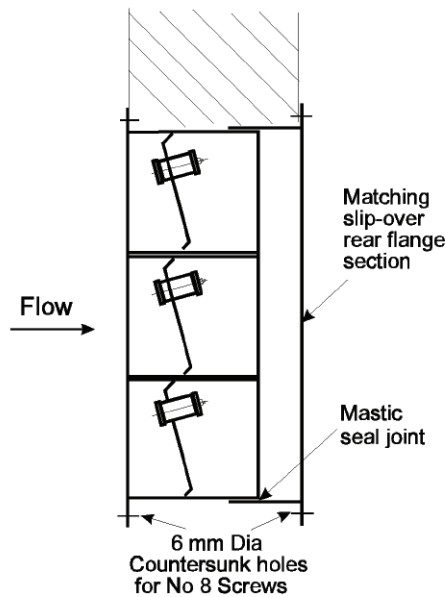

product ranges



Air pressure stabilisers for use in hospitals.



Premium range air pressure control valves for the pharmaceutical industry.



Air pressure control valves for protected escapes routes.



Heavy duty valves for specialist industrial and defence applications.



Valves for the control of pressure within gas fire suppression systems.